



E 46

ISI YALITIMLI KALDIR - SÜR SİSTEMLERİ

INSULATED LIFT & SLIDE SYSTEMS



E 46

PROFİLLER

PROFILES

ISI YALITIMLI KALDIR - SÜR SİSTEMLER
INSOLATED LIFT&SLIDE SYSTEM

COD Code	AGIRLIK (kg/m) Weight	Jxx cm ⁴	Jyy cm ⁴	Wxx cm ³	Wyy cm ³	L m
4266	2,540	15,65	99,28	—	—	6
4267	1,962	18,82	201,77	—	—	6
4284	0,591	18,82	201,77	—	—	6

4266

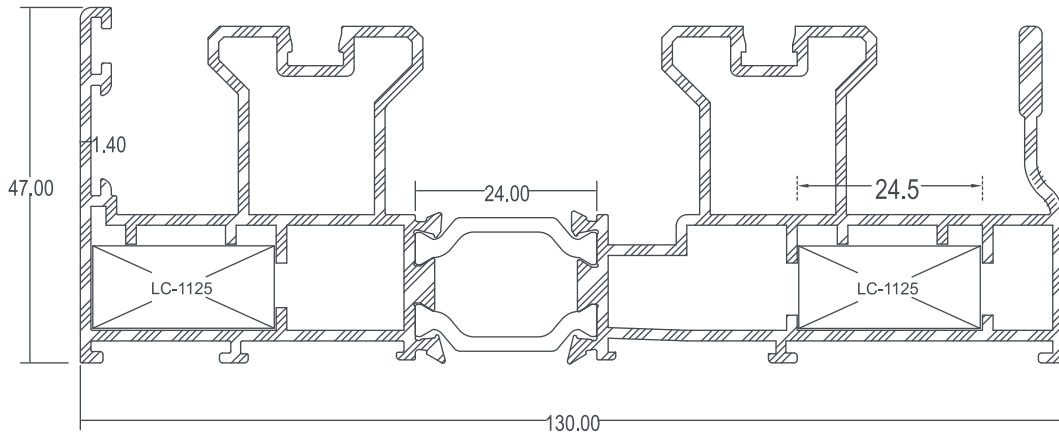

4267

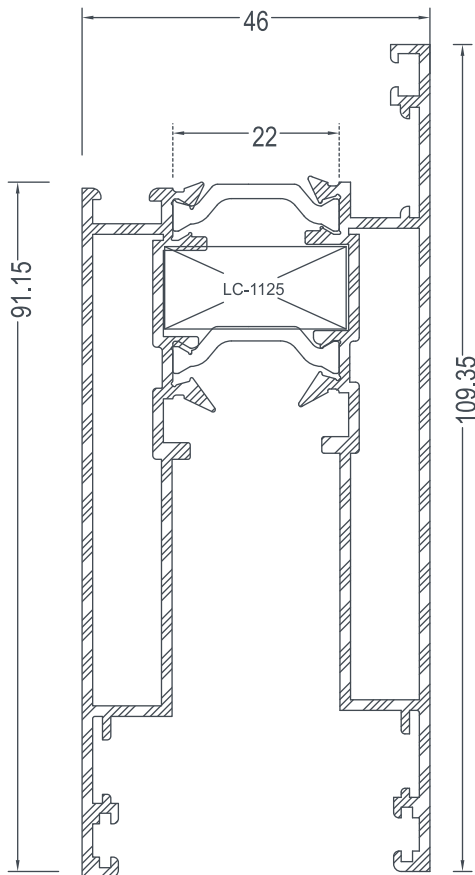

4284

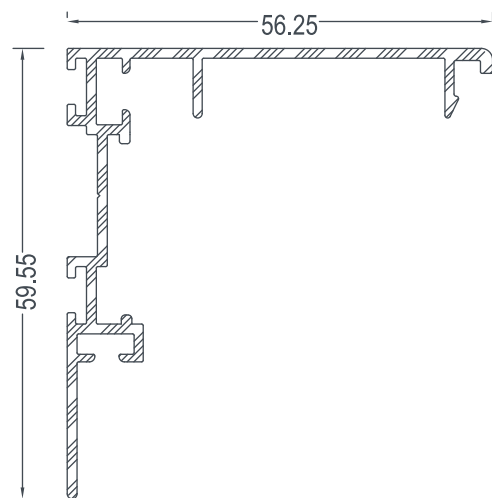



COD Code	AGIRLIK (kg/m) Weight	Jxx cm ⁴	Jyy cm ⁴	Wxx cm ³	Wyy cm ³	L m
4262	2,277	15,65	99,28	—	—	6
4264	2,744	18,82	201,77	—	—	6

4262

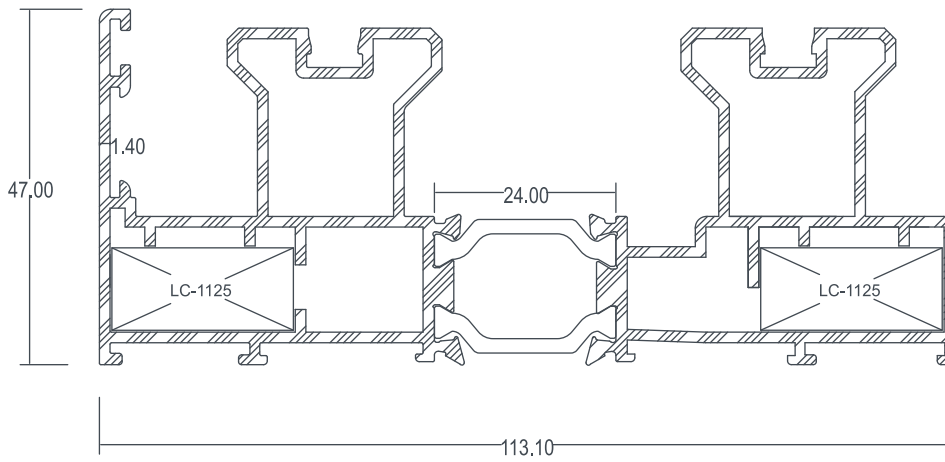

4264

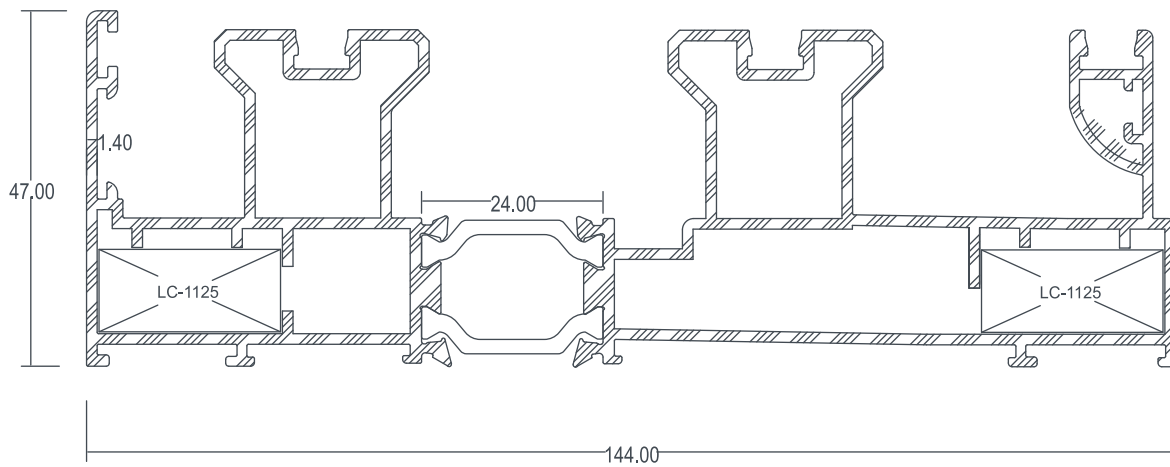

COD Code	AGIRLIK (kg/m) Weight	Jxx cm4	Jyy cm4	Wxx cm3	Wyy cm3	L m
4263	1,604	25,36	15,98	—	—	6
4265	1,042	3,44	5,94	—	—	6
4063	0,567	9,02	2,26	—	—	6
4065	0,981	23,01	4,27	—	—	6

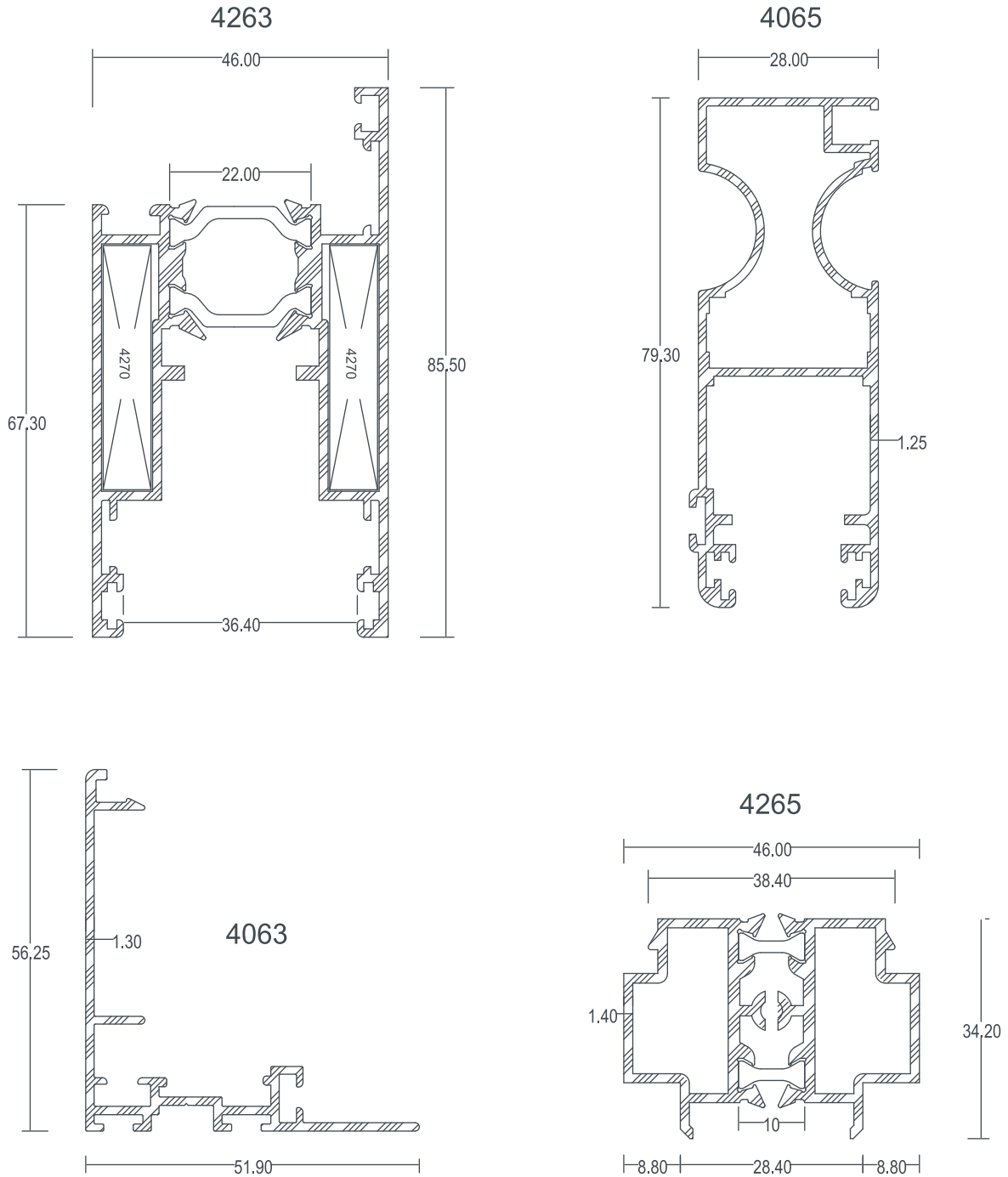



COD Code	AGIRLIK (kg/m) Weight	Jxx cm ⁴	Jyy cm ⁴	Wxx cm ³	Wyy cm ³	L m
4062	0,174	----	----	----	----	6
4064	0,125	----	----	----	----	6
4271	0,224	----	----	----	----	6
4270	4,601	----	----	----	----	6
4273	0,177	----	----	----	----	6
1004	0,257	----	----	----	----	6

4062

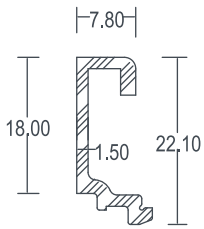

4064

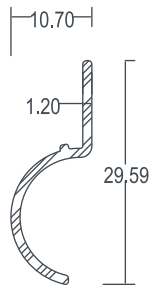

4271

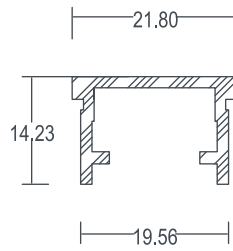

1004

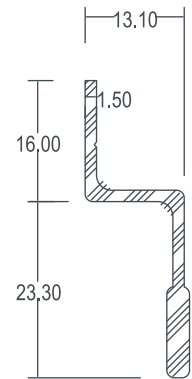

4270

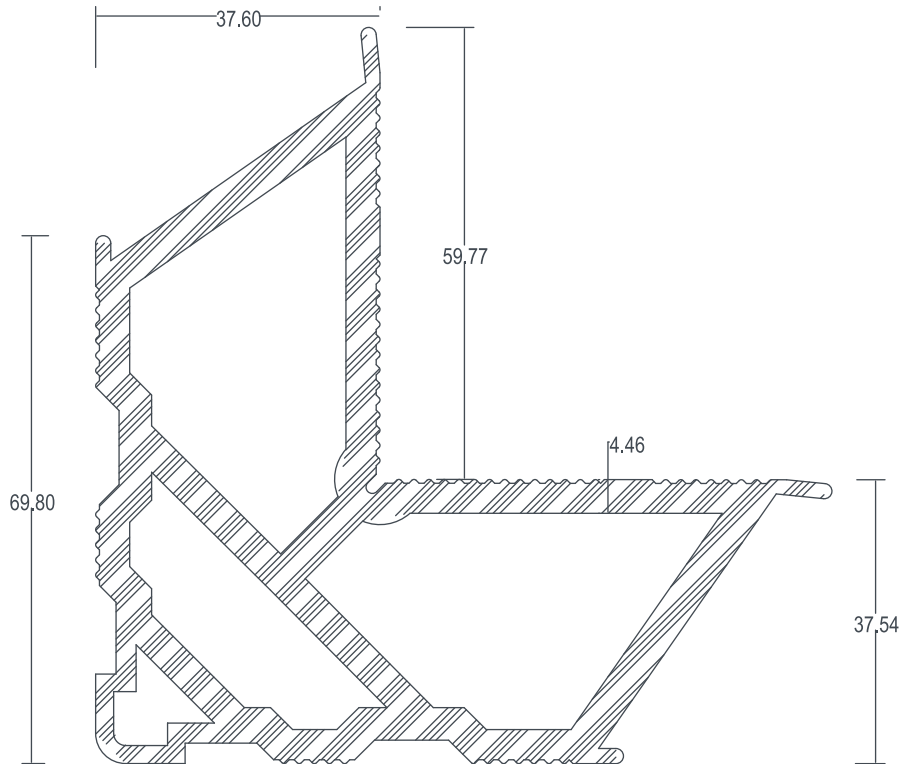

4273



E 46

DETAYLAR
DETAILS

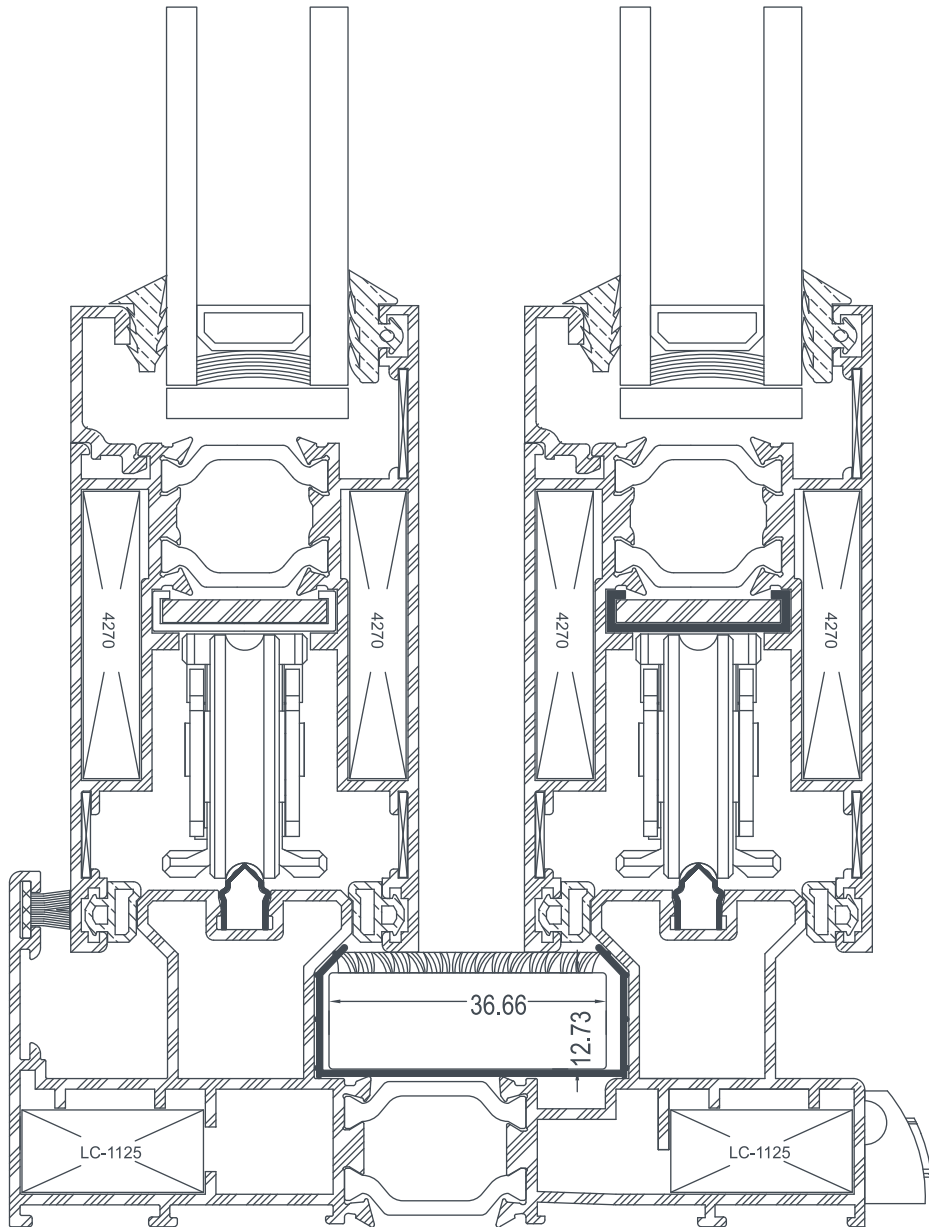

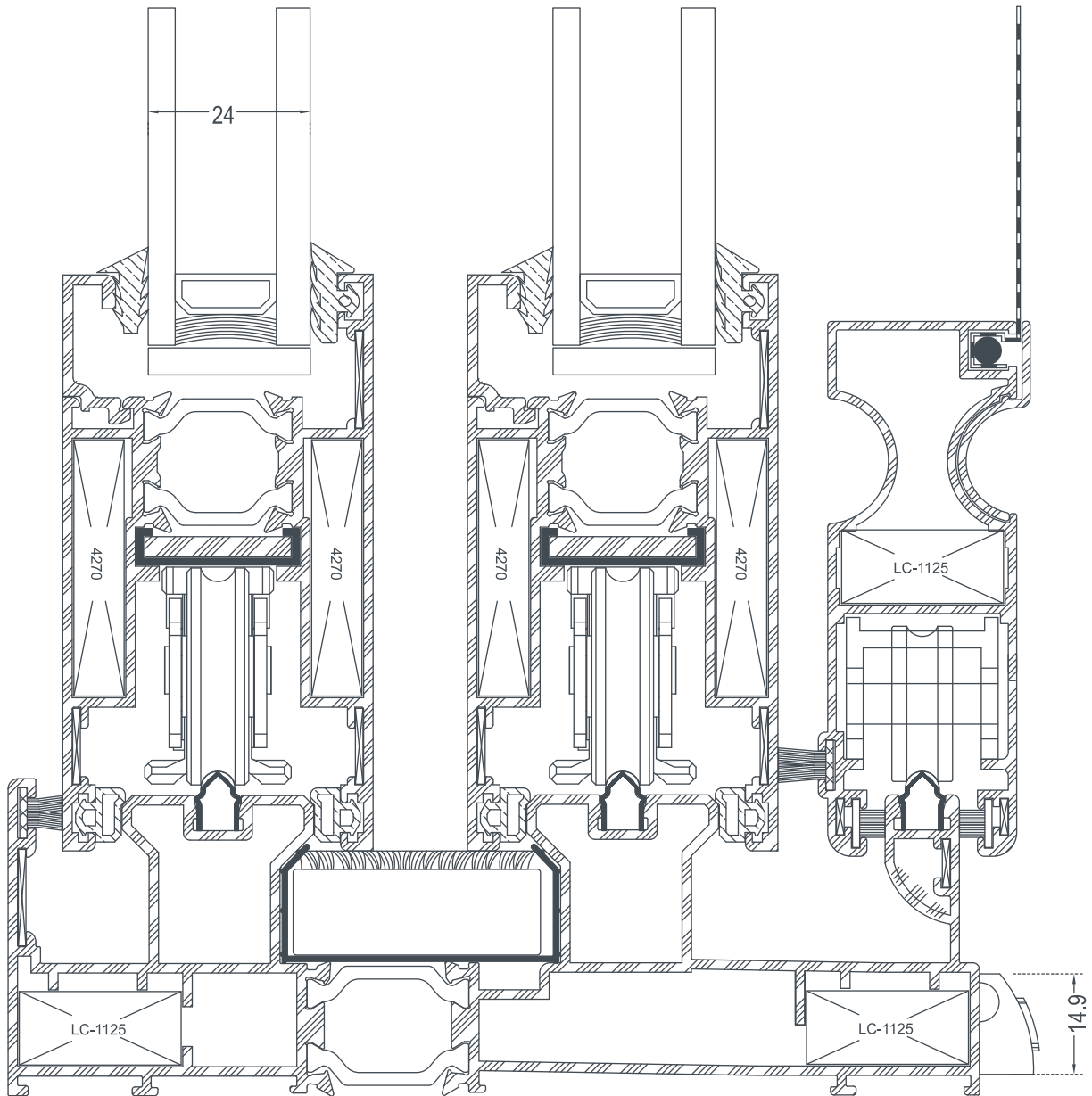

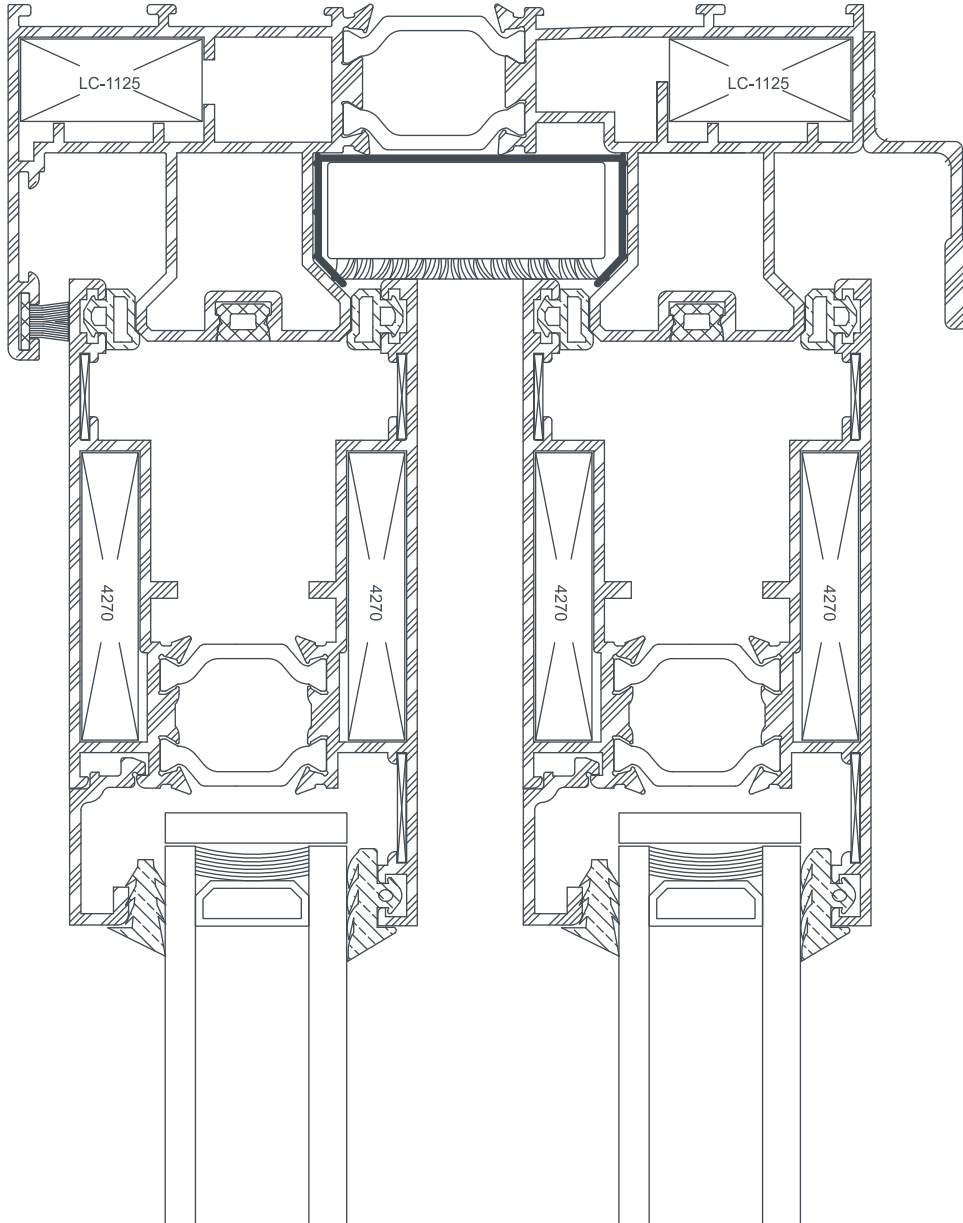

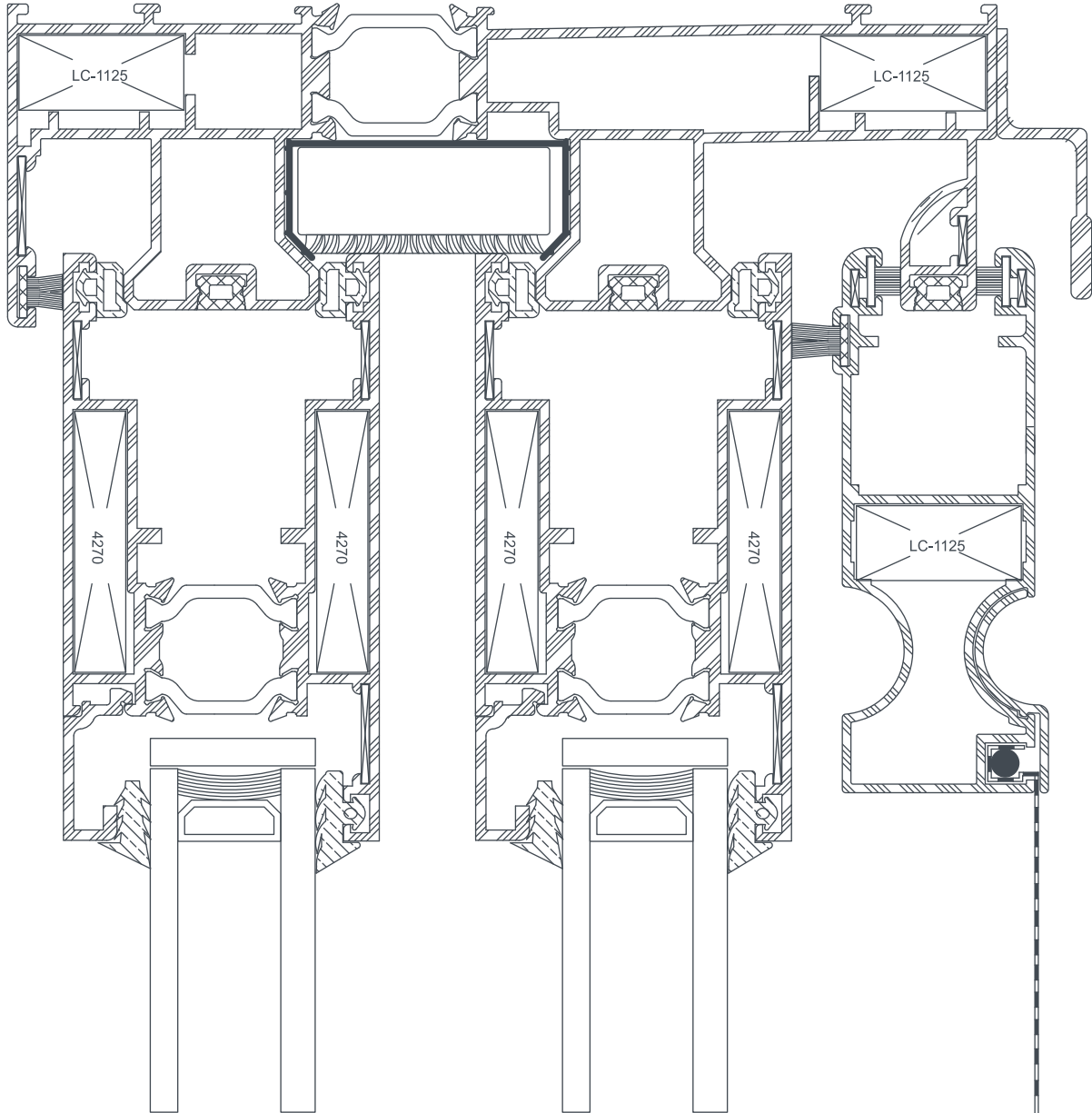

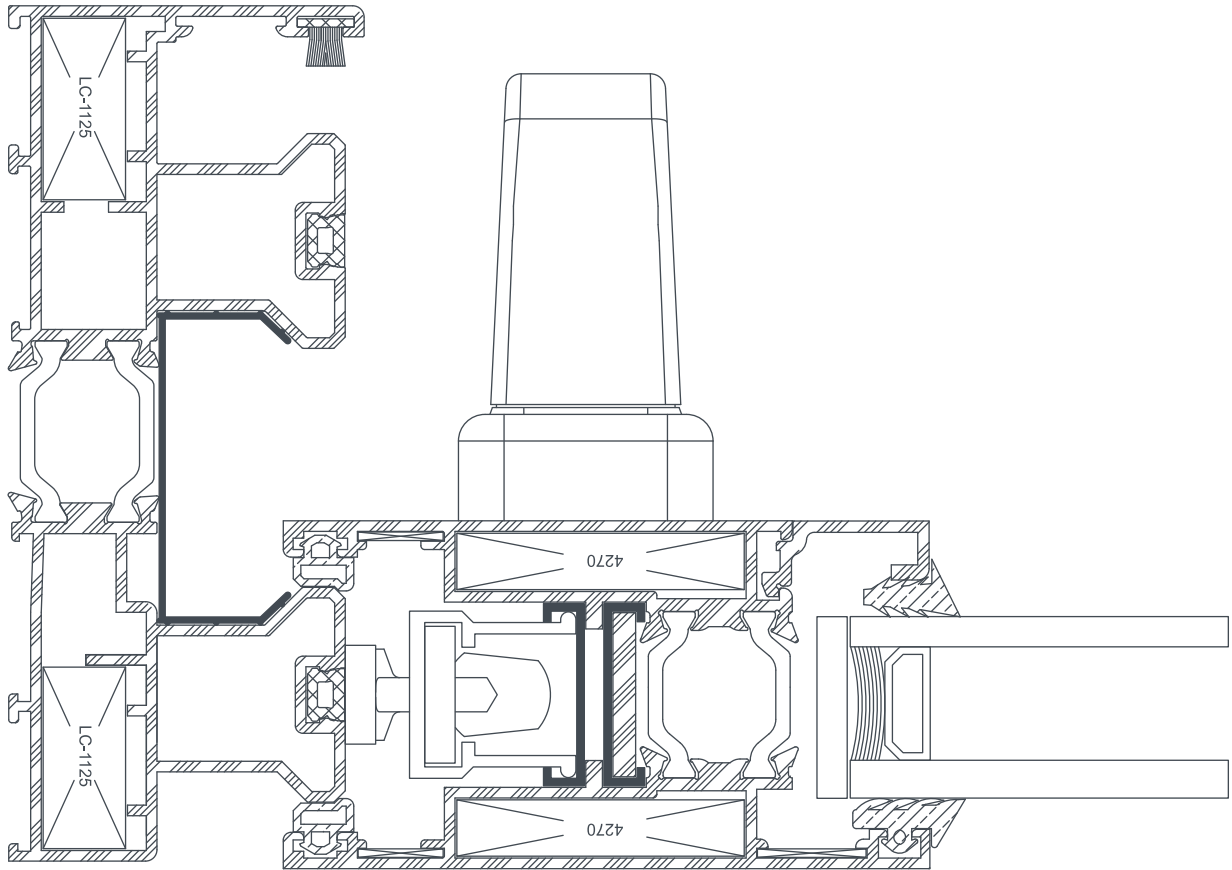

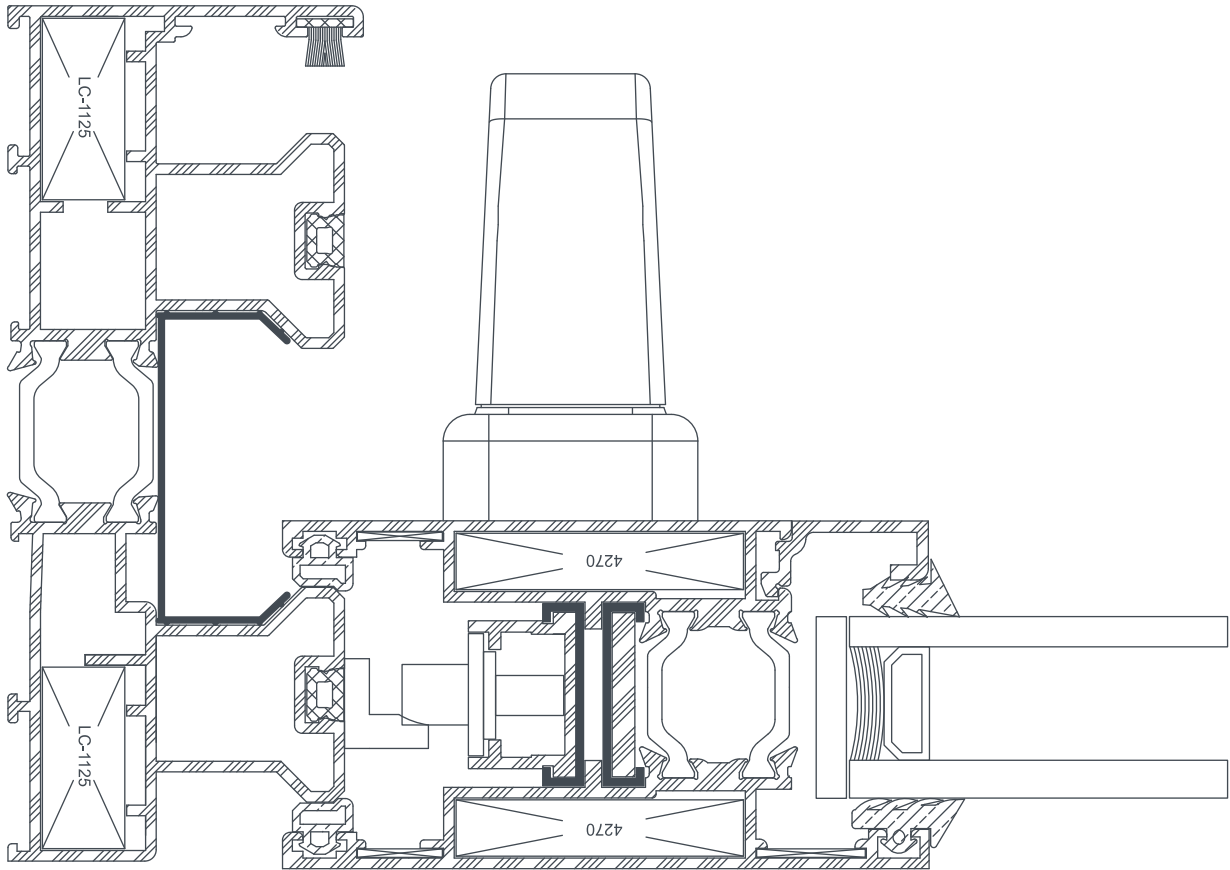

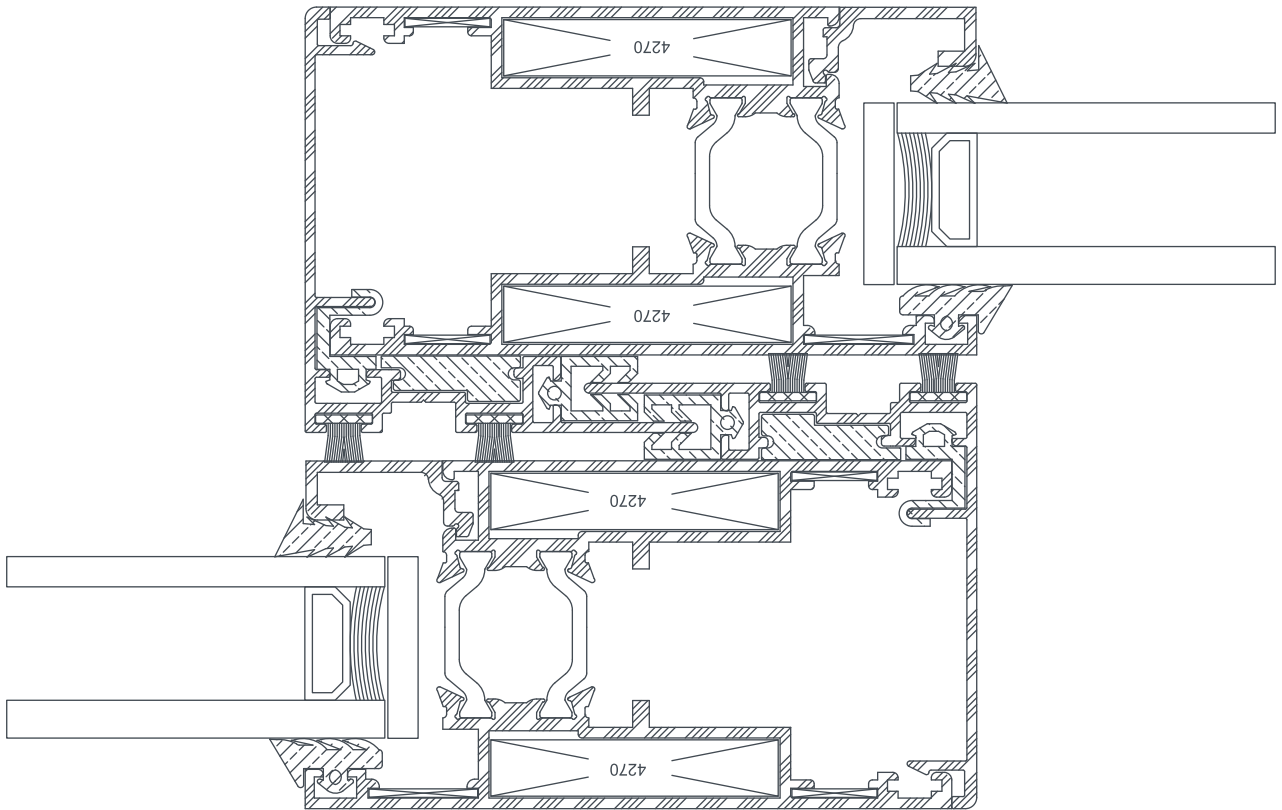

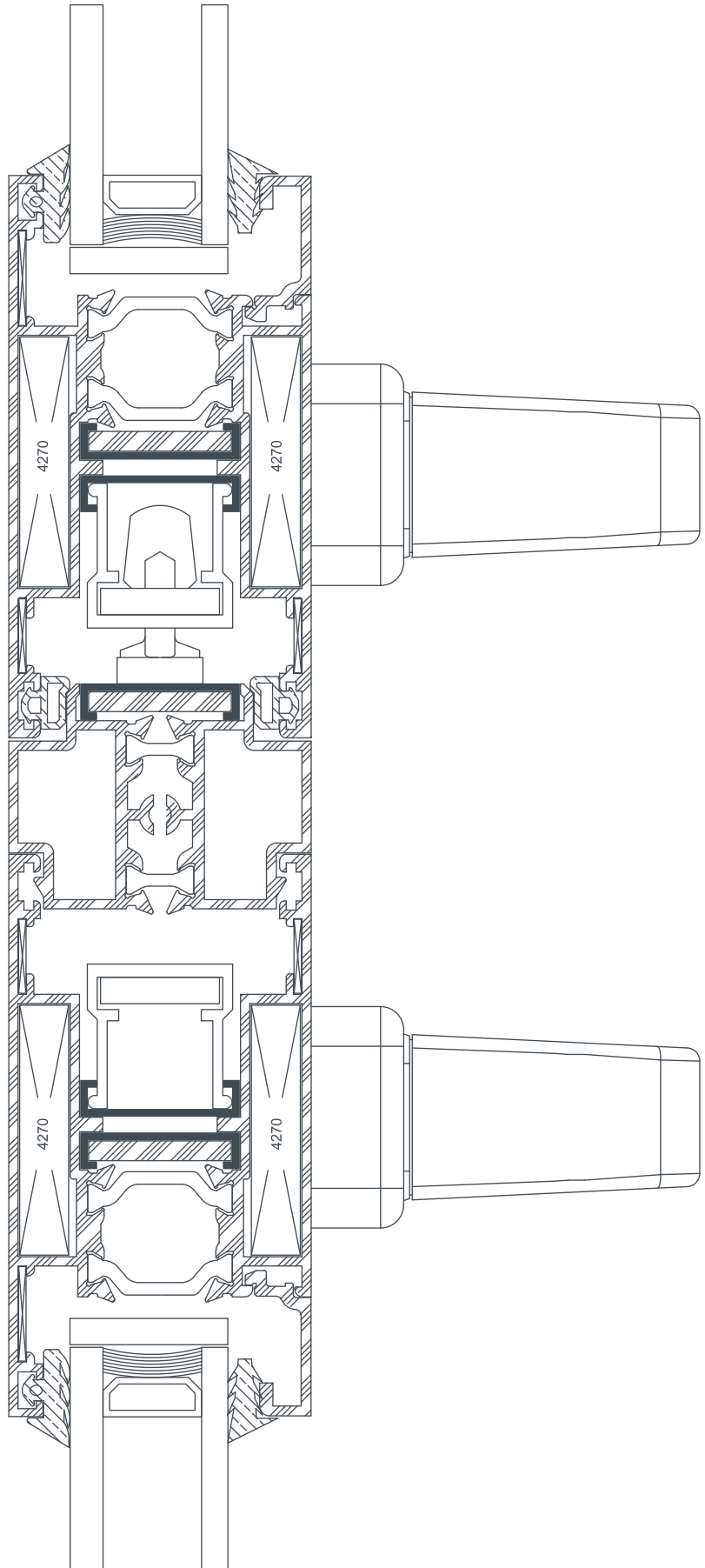

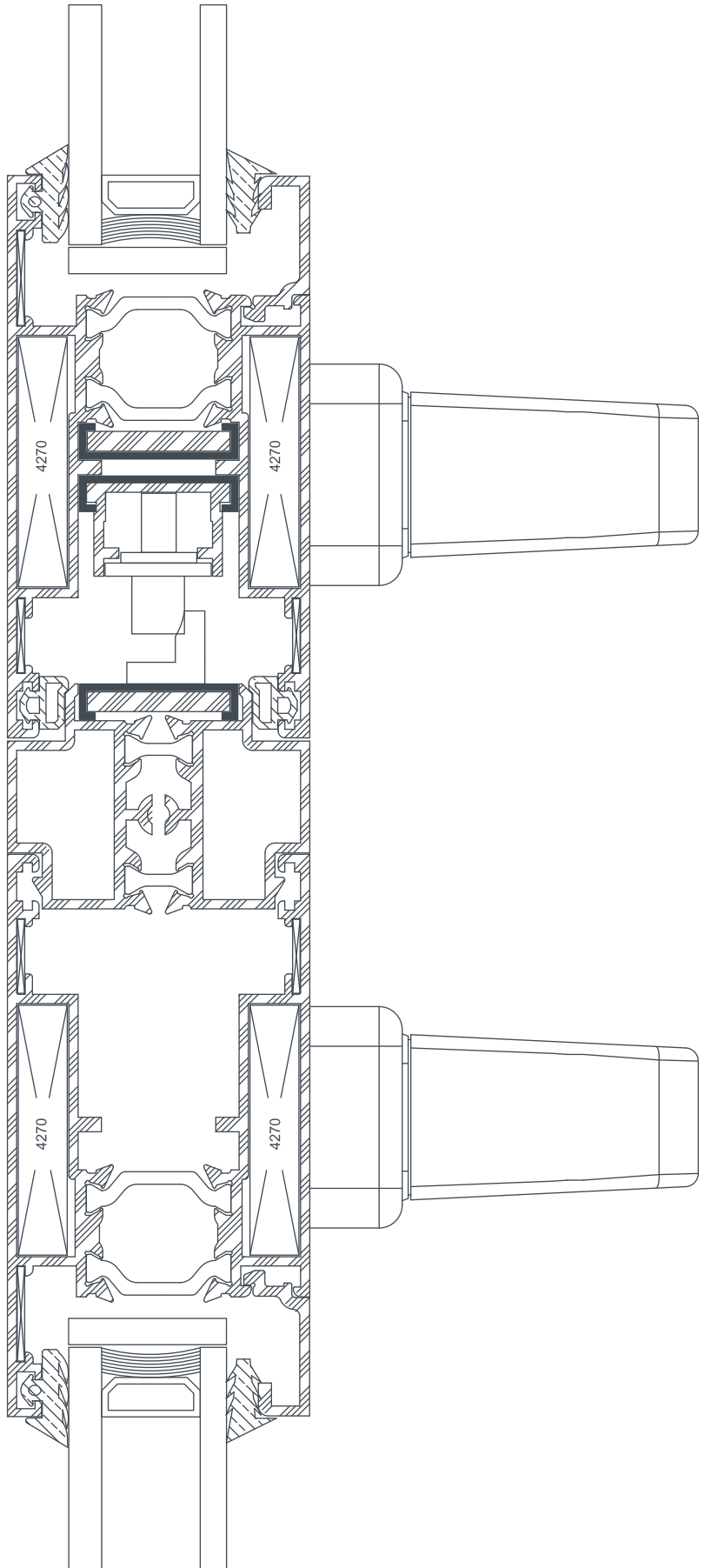











E 46





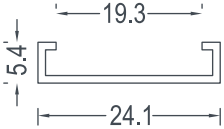

AKSESUARLAR

ACCESSORIES

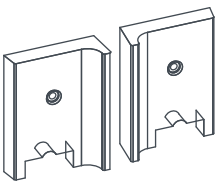
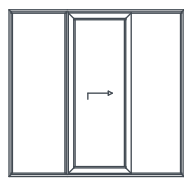
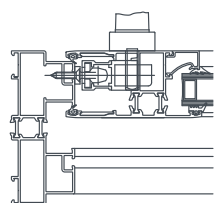

	E-01-051 Ray Fitili Rail gasket 40 gr/mt			E-01-072 Dış cam fitili outside gasket	
	E-01-027 iç cam fitili inside gasket 54 gr/mt			E-01-073 Dış cam fitili outside gasket	
	E-01-028 Dış cam fitili outside gasket 60 gr/mt			ES - 2 Tozluk Leggings ADET	
	E-01-070 Dış cam fitili outside gasket			ES - 22 B-9281 Kızak 6,2 mt/boy	
	E-01-071 Dış cam fitili outside gasket			ES - 1 Kasa " U " Plastiği " U " Plastic 6,2 mt/boy	

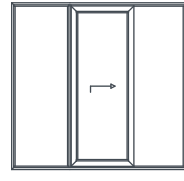
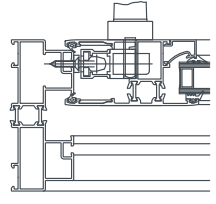

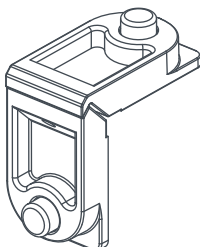
	ES - 5 Çelik Ray Steel Rail 6,2 mt/boy			KIL-3 Kil fitil Brush	
	ES - 23 Kapak (Pvc) Cover (Pvc) (Alt & Üst) (Lower & Upper) ADET			E-07-002-300kg Kaldır-Sür Aksesuarı Lift&Slide Accessories	
	E-10-002 STP-274001 Köşe Çavuşu Corner joint			E-07-002-200kg Kaldır-Sür Aksesuarı Lift&Slide Accessories	
	ES - 24 E-04-020 Tahliye Tapası ADET				
	LC - 1125 Kasa Köşe Takoğu Frame corner wenge (Alt & Üst) (Lower & Upper) ADET	